











-  Ponte elettroidraulico a forbice
-  **Electro-hydraulic scissor lift**
-  Elektrohydraulische Scherenhebebühne
-  Pont ciseaux électro-hydraulique
-  Elevador electro-hidráulico de tijera



Su versioni 'LT' e 'ATLT': Sollevatore ausiliario da 4,0 t
On 'LT' and 'ATLT' versions: Lifting table with 4,0 t capacity
 Für Ausführungen 'LT' und 'ATLT': Radfreiheber 4,0 t Tragkraft
 Sur versions 'LT' et 'ATLT': Levage auxiliaire capacité 4,0 t
 En versiones 'LT' y 'ATLT': elevador auxiliar de 4,0 t

-  Sincronismo idraulico delle pedane • Sicurezza idraulica composta da 2 circuiti volumetrici • Sicurezza idraulica in caso di sovraccarico • Sicurezza idraulica in caso di rottura dei tubi • Pompa manuale in caso di assenza di energia elettrica • Comandi uomo presente, 24V • Doppio cilindro nelle torrette (LT e ATLT) • Serie 4 tamponi in gomma (LT e ATLT) • Incavi anteriori e piastre oscillanti posteriori per assetto ruote sui modelli AT e ATLT • Guide laterali per traverse idrauliche • Segnale acustico ultimo tratto di discesa • Sicurezza meccanica fra i cilindri per un perfetto livellamento delle piattaforme (versioni AT/ATLT) - OPZIONE 1: Kit da incasso L1368 - OPZIONE 2: kit per sopra pavimento L 973
-  **Hydraulic platforms' synchronization • 2 independent hydraulic circuits • Overload safety valve • Safety valve in the event of sudden loss of pressure • Manual descent system in the event of power failures • 24V "dead man" controls • auxiliary lifting tables with double cylinders' system and 4 rubber pads (LT and ATLT versions) • Set of 4 rubber pads (LT and ATLT) • Front recesses and rear slip plates for wheel alignment (AT and ATLT versions) • Lateral rails for jack ing beams • Acoustic warning in the last portion of descent • Mechanical locks between the cylinders for a perfect levelling of the platforms (AT and ATLT versions) - OPTION 1: recessed installation kit L1368 - OPTION 2: on floor installation kit L973**
-  Hydraulische Gleichlaufregulierung der Fahrschienen • Hydraulische Sicherheitseinrichtung besteht aus 2 volumetrischen Schaltungen • Überlastsicherung mittels Überdruckventil • Rohrbruchsicherung • Handpumpe zum manuellen Absenken bei Stromausfall • Totmann-Steuerung (24 V-Niederspannung) • Radfreiheber mit Doppelzylinder (LT und ATLT) • Fahrzeugaufnahme-Gummiblöcke 4 stk. (LT und ATLT) • Vordere Aussparungen und hintere Schiebeplatten für Achsvermessung auf • Mechanische Klinken zwischen den Zylindern für eine perfekte Nivellierung der Plattformen (AT und ATLT Versionen) - Version 1: Bodenebeneneinbau Satz L1368 - Version 2: Auf Boden L973
-  Synchronisation hydraulique des plateformes • Dispositif de sécurité hydraulique composé de 2 circuits volumétriques • Sécurité hydraulique en cas de surcharge • Sécurité hydraulique en cas de rupture de tuyauterie • Pompe manuelle de descente en cas de coupure de courant • Commandes de type "homme mort" à 24V • Levage auxiliaire avec double vérin (LT et ATLT) • Jeux de 4 tampons en caoutchouc (LT et ATLT) • Encastrement avant et plateaux de réalignement arrière pour géométrie sur les modèles AT et ATLT • Rails latéraux pour traverse hydraulique • Signal sonore sur la dernière partie de descente • Sécurités mécaniques entre les cylindres pour une parfaite mise à niveau des plates-formes (versions ATLT et AT) - OPTION 1: kit pour encastrement L1368 - OPTION 2: kit pour montage sur le sol L973
-  Sincronización hidráulica de las plataformas • Dispositivo de seguridad hidráulico consta de 2 circuitos volumétricos • Seguridad hidráulica contra sobrecarga • Seguridad hidráulica en caso de rotura tubos • Bomba manual para el caso de corte de la corriente • Mandos de hombre presente, 24V • Torretas con doble cilindro (LT y ATLT) • Juego de 4 tacos en goma (LT y ATLT) • Asientos delanteros y platos oscilantes traseros para alineación de las ruedas en modelos AT y ATLT • Guías laterales para travesaños hidráulicos • Señal acústica último tramo de descenso • Cerraduras mecánicas entre los cilindros para una perfecta nivelación de las plataformas (AT y versiones ATLT) - OPCION 1: kit para empotrar L 1368 - OPCION 2: kit para instalacion al suelo L973

SATURNUS EV50

5,0 t

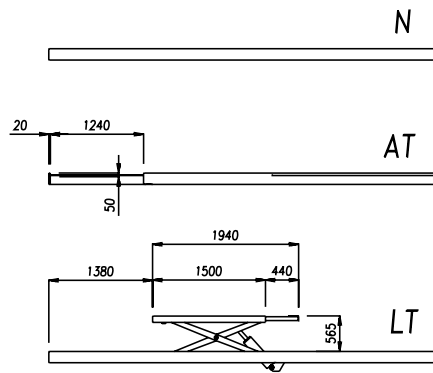
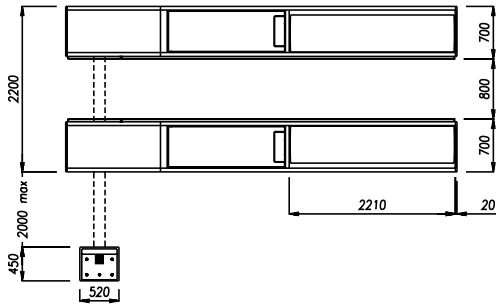

- Sicurezza meccanica
- Mechanical locking system AT-ATLT

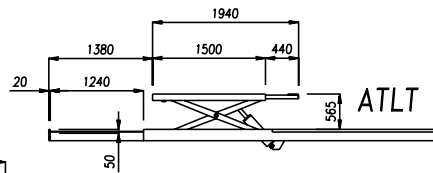
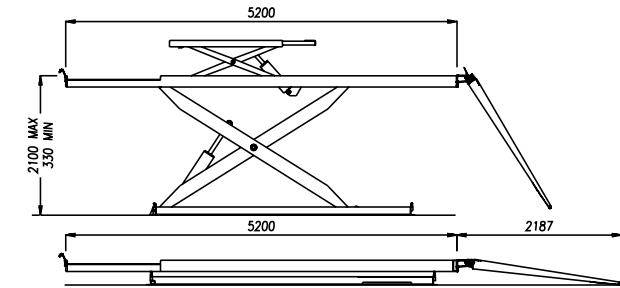

- Quadro comando
- Control panel



Dati tecnici

Technical data

Technische Eigenschaften

Caractéristiques techniques

Datos técnicos

Funzionamento • Operation • Funktionsweise • Fonctionnement • Funcionamiento	Elettroidraulico • Electro-hydraulic • Elektrohydraulisch • Électrohydraulique • Electro-hidráulico
Portata • Capacity • Tragfähigkeit • Capacité • Capacidad	5000 kg
Peso • Weight • Gewicht • Poids • Peso	1500-2300 kg
Salita/Discesa • Lifting/lowering • Hub/Senkzeit • Levage/descente • Subida/bajada	40 s - 30 s • Optional INVERTER 22 s - 30 s
Altezza di sollev. • Lifting height • Hubhöhe • Hauteur de levage • Altura de elevación	2100 mm + (565 mm**)
Altezza minima* • Min. height* • Mindesthöhe* • Hauteur min.* • Altura mínima*	330 mm
Motore • Motor • Motorleistung • Puissance moteur • Motor	4 kW - 230-400 V/50 Hz 3 ph
Alimentazione pneumatica • Pneumatic feed • Betriebsdruck • Alimentation pneumatique • Alimentación neumática	6 - 8 bar

*: da pavimento / from floor / ab Boden / du sol / desde el nivel del suelo

**ATLT - LT



Opzioni

Optionals

Sonderzubehör

Options

Opcionales

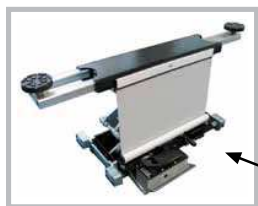

Traversa idraulica
Jacking beam
Zusatz-Radfrehheber
Traverse de evage
Travesaño hidráulico



- Prolunghe per tubi idraulici (1 m / 2 m)
- Hose extensions (1 m / 2 m)
- Schlauchverlängerungen (1 m / 2 m)
- Rallonges pour tuyaux hydrauliques (1 m / 2 m)
- Prolongaciones para tubos hidráulicos (1 m / 2 m)



- Traverse per veicoli speciali
- Crosspieces for special vehicles
- Traversen für Sonderfahrzeuge
- Traverses pour véhicules spéciaux
- Travesaños para los vehículos especiales



INVERTER
INVERTER
INVERTER
INVERTER

- Kit illuminazione
- Illumination kit
- Beleuchtungsset
- Kit d'éclairage
- Kit de la iluminación

- Serie rampe salita/discesa (2)
- Drive-on / Drive-off ramps (2)
- Auf- und Abfahrampen (2)
- Rampes de montée/descente (2)
- Juego de rampas de acceso al elevador (2 unidades)

- Dispositivo ricerca 2 posizioni di stazionamento
- Electronic device for 2 parking position
- Elektronische 2-Parkpositionen Vorrichtung
- Dispositif de recherche des deux positions de stationnement
- Aparato de búsqueda de 2 posiciones de aparcamiento

- Provagiochi
- Play detector
- Gelenkspieltester
- Plaques à jeux
- Detector de holguras